



2017 SPEC BOOK



**Round Front Toilet**



**MaP Result (Flush)**

1000 gram

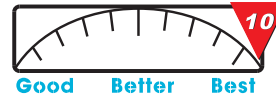

Toilet Seat not Included

Fixture dimensions and hydraulic performance meet or exceed ANSI/ASME standard A112.19.2M and CAN/CSA B-45 requirements.

	<b>Model</b>	<b>Color</b>
<b>Tank</b>	571-6914	White
<b>Bowl</b>	571-6913	White

**Delano HET Round Front 1.28GPF 3" Flush Toilet**

**DESCRIPTION**

- \* 1.28 GPF (4.8LPF) Siphon Jet Flush
- \* 15" (382mm) Rim Height
- \* Large Water Surface
- \* 2" Wide Fully Glazed Trapway
- \* 12" Rough-in
- \* High Performance Flushing System

Project / Job Name			
Architect / Engineer			
Contractor			
Model		Q'ty	
Notes :			



**Round Front Toilet**

**SPECIFICATIONS**

- \* Water Use : 4.8Lpf/1.28Gpf
- \* Trap Diameter : 2"
- \* Rough-in : 12"
- \* Trap Seal : 2"
- \* Min. Water Pressure : 28 psi
- \* Water Surface : 8-5/8" x 6-7/8"
- \* Flush System : Siphon Jet Gravity Flushing System
- \* Warranty : Five Years Limited Warranty
- \* Material : Tank & Bowl: Vitreous China
- \* Shipping Weight : Tank: 30.75LBS  
Bowl: 43LBS
- \* Shipping Dimensions : Tank: 18-1/8" x 9" x 15-3/4"  
Bowl: 26" x 9-7/8" / 15-3/4" x 16-5/16"

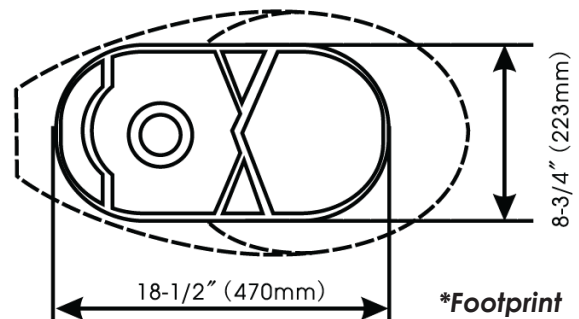
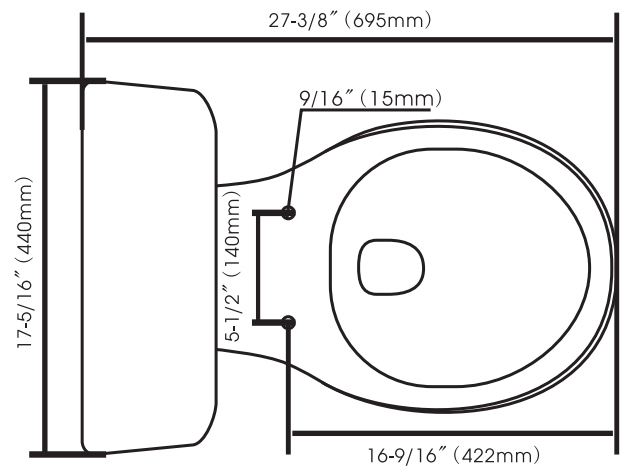
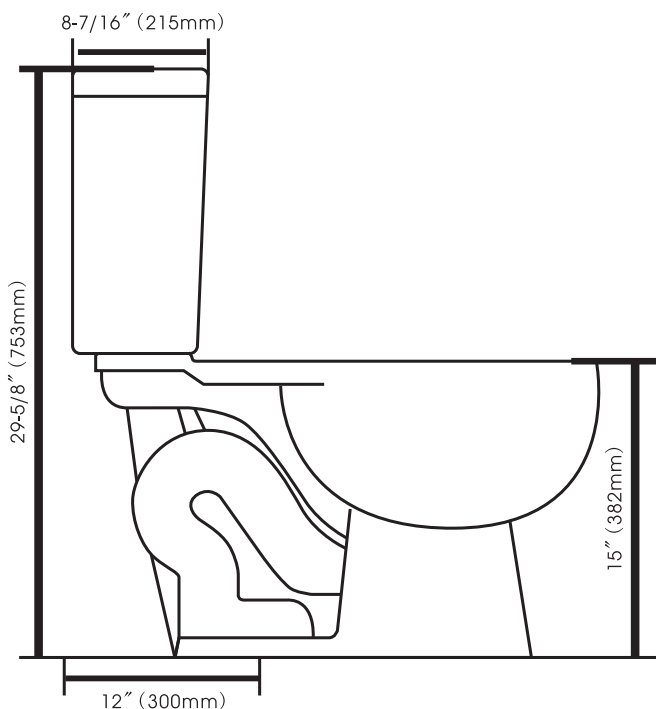

**Dimensions In Inches And Millimeters**

**Dimensions Are Subject To A Variance Of +/-5%**



**Elongated Toilet**



**MaP Result (Flush)**

1000 gram

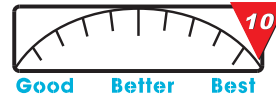

Toilet Seat not Included

Fixture dimensions and hydraulic performance meet or exceed ANSI/ASME standard A112.19.2M and CAN/CSA B-45 requirements.

	Model	Color
Tank	571-6914	White
Bowl	571-5789	White

**Delano HET Elongated 1.28GPF 3" Flush Toilet**

**DESCRIPTION**

- \* 1.28 GPF (4.8LPF) Siphon Jet Flush
- \* 15" (382mm) Rim Height
- \* Large Water Surface
- \* 2" Wide Fully Glazed Trapway
- \* 12" Rough-in
- \* High Performance Flushing System

Project / Job Name			
Architect / Engineer			
Contractor			
Model		Q'ty	
Notes :			



**Elongated Toilet**

**SPECIFICATIONS**

- \* Water Use : 4.8Lpf/1.28Gpf
- \* Trap Diameter : 2"
- \* Rough-in : 12"
- \* Trap Seal : 2"
- \* Min. Water Pressure : 28 psi
- \* Water Surface : 8-5/8" x 6-7/8"
- \* Flush System : Siphon Jet Gravity Flushing System
- \* Warranty : Five Years Limited Warranty
- \* Material : Tank & Bowl: Vitreous China
- \* Shipping Weight : Tank: 30.75LBS  
Bowl: 44LBS
- \* Shipping Dimensions : Tank: 18-1/8" x 9" x 15-3/4"  
Bowl: 27-3/8" x 9-7/8" / 15-3/4"  
x 16-5/16"

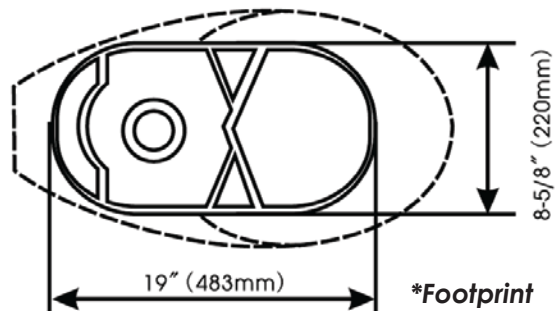
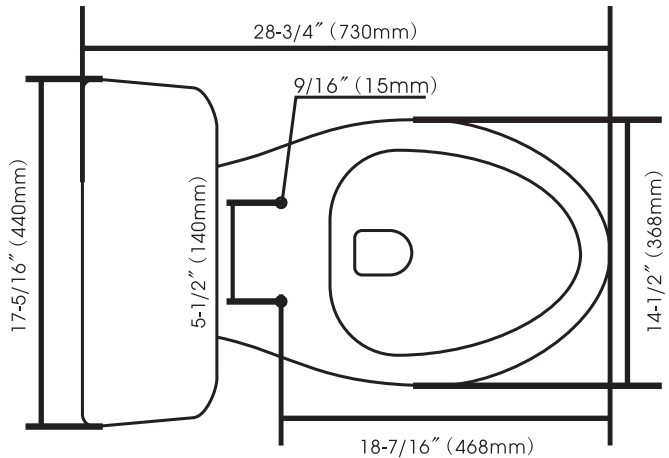
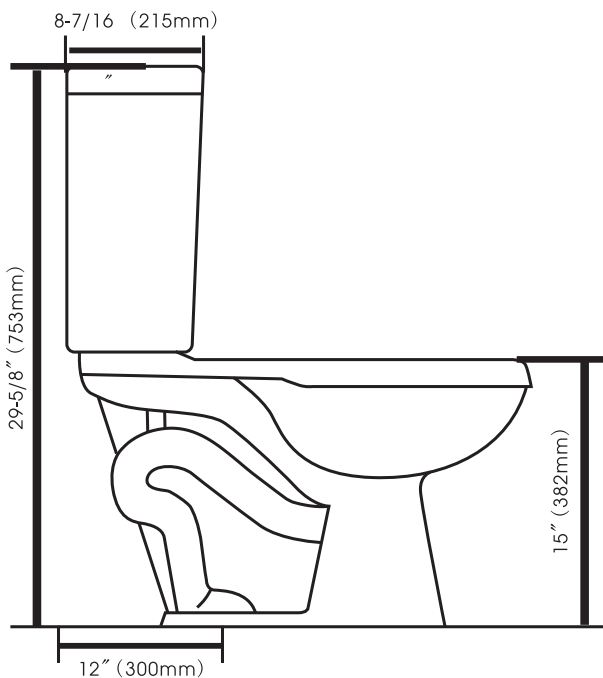

**Dimensions In Inches And Millimeters**

**Dimensions Are Subject To A Variance Of +/-5%**



**ADA Elongated Toilet**



**MaP Result (Flush)**

1000 gram



Toilet Seat not Included

Fixture dimensions and hydraulic performance meet or exceed ANSI/ASME standard A112.19.2M and CAN/CSA B-45 requirements.



	Model	Color
Tank	571-6914	White
Bowl	571-6915	White

**Delano HET ADA Elongated 1.28GPF 3" Flush Toilet**

**DESCRIPTION**

- \* 1.28 GPF (4.8LPF) Siphon Jet Flush
- \* 16 5/16" (414mm) Rim Height
- \* Large Water Surface
- \* 2" Wide Fully Glazed Trapway
- \* 12" Rough-in
- \* Chrome Trip Lever
- \* High Performance Flushing System

Project / Job Name			
Architect / Engineer			
Contractor			
Model		Qty	
Notes :			



**ADA Elongated Toilet**

**SPECIFICATIONS**

- \* Water Use : 4.8Lpf/1.28Gpf
- \* Trap Diameter : 2"
- \* Rough-in : 12"
- \* Trap Seal : 2"
- \* Min. Water Pressure : 28 psi
- \* Water Surface : 8-5/8" x 6-7/8"
- \* Flush System : Siphon Jet Gravity Flushing System
- \* Warranty : Five Years Limited Warranty
- \* Material : Tank & Bowl: Vitreous China
- \* Shipping Weight : Tank: 30.75LBS  
Bowl: 46.25LBS
- \* Shipping Dimensions : Tank: 18-1/8" x 9" x 15-3/4"  
Bowl: 26-3/4" x 10" / 15-3/4"  
x 18-1/8"

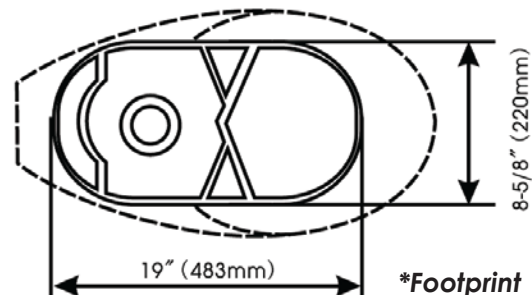
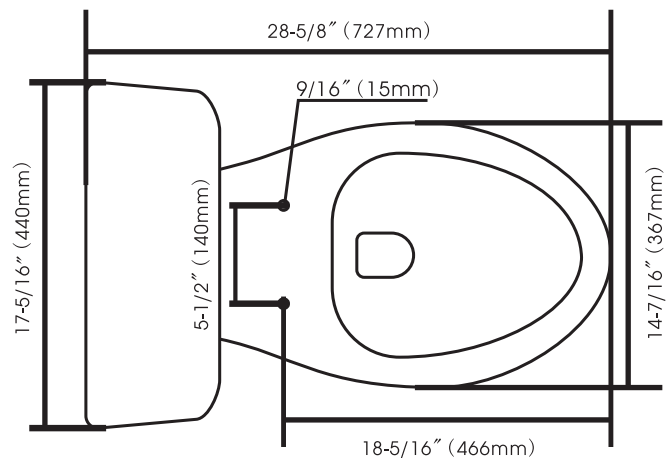
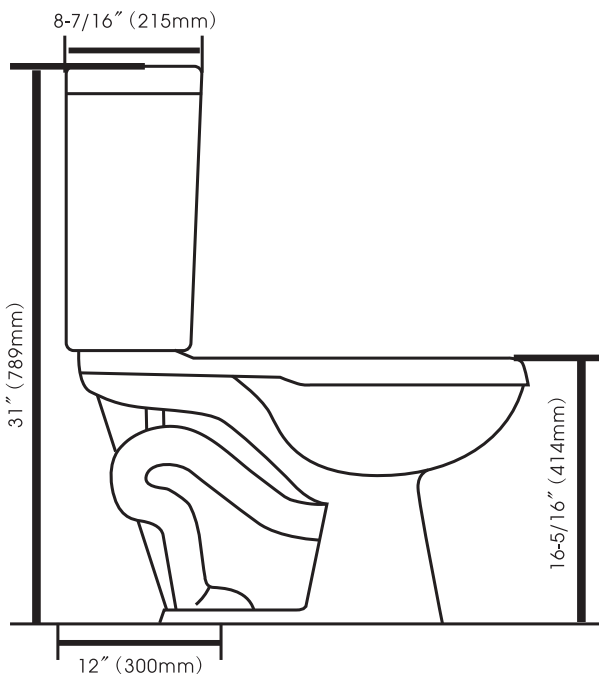

**Dimensions In Inches And Millimeters**

**Dimensions Are Subject To A Variance Of +/-5%**



**Toilet Tank**

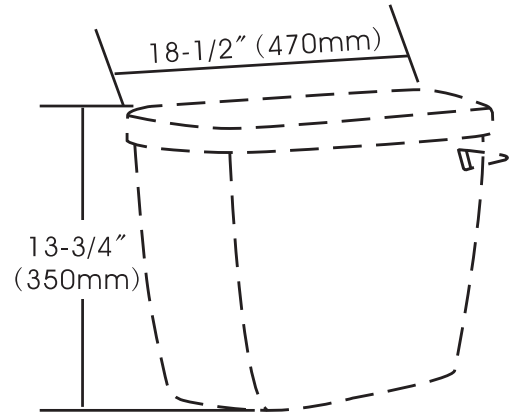

Fixture dimensions and hydraulic performance meet or exceed ANSI/ASME standard A112.19.2M and CAN/CSA B-45 requirements.



<b>Model</b>	<b>Color</b>
571-8655	White

**Delano 1.28GPF HET 3" Flush Right Hand Tank**

**DESCRIPTION**

- \* Water Saving Unit - 1.28GPF
- \* Upgrade Fill and Flush Valve System
- \* High Performance Flushing System
- \* Color Matched Tank Handle
- \* Works with Delano Toilet Bowl 571-6913, 572-5789 & 571-6915
- \* ADA compliant when paired with the 571-6915



Project / Job Name			
Architect / Engineer			
Contractor			
Model		Qty	
Notes :			





**Toilet Tank**

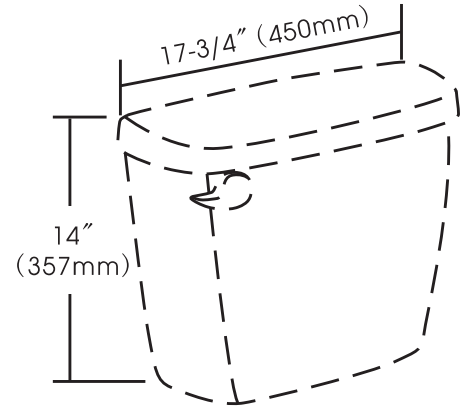

Fixture dimensions and hydraulic performance meet or exceed ANSI/ASME standard A112.19.2M and CAN/CSA B-45 requirements.



<b>Model</b>	<b>Color</b>
572-5737	White

**Delano 1.28GPF HET 3" Flush 10" Tank**

**DESCRIPTION**

- \* Water Saving Unit - 1.28GPF
- \* For 10" Rough-in Applications
- \* Upgrade Fill and Flush Valve System
- \* High Performance Flushing System
- \* Color Matched Tank Handle
- \* Works with Delano Toilet Bowl 571-6913, 572-5789 & 571-6915



Project / Job Name			
Architect / Engineer			
Contractor			
Model		Qty	
Notes :			



**Toilet Tank**

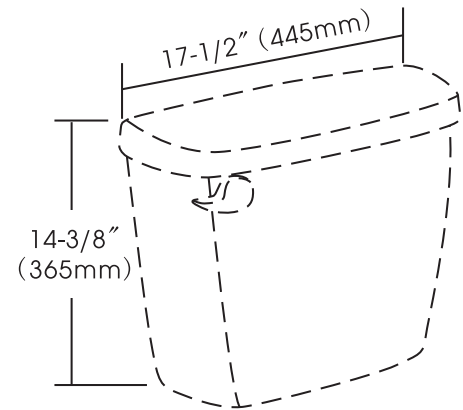

Fixture dimensions and hydraulic performance meet or exceed ANSI/ASME standard A112.19.2M and CAN/CSA B-45 requirements.

<b>Model</b>	<b>Color</b>
572-6234	White

**Delano 1.28GPF HET 3" Flush 14" Tank**

**DESCRIPTION**

- \* Water Saving Unit -- 1.28GPF –
- \* Upgrade Fill And Flush Valve System
- \* High Performance Flushing System
- \* Color Matched Tank Handle
- \* Works with Salinas Toilet Bowl

Project / Job Name			
Architect / Engineer			
Contractor			
Model		Q'ty	
Notes :			



**Round Front Toilet**

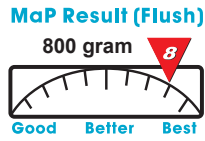

**“Grab-N-Go”**

This Package Includes :



※ Tank & Bowl

+

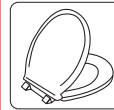

※ Toilet Seat

+

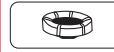

※ Wax Ring with Sleeve

+

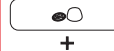

※ Two Bolt Caps

+



※ Two Flange Bolts

Fixture dimensions and hydraulic performance meet or exceed ANSI/ASME standard A112.19.2M and CAN/CSA B-45 requirements.



<b>Model</b>	<b>Color</b>
572-5833	White

**Grab-N-Go Round Front 1.28GPF 3” Flush Toilet**

**DESCRIPTION**

- \* 1.28 GPF (4.8 LPF) Siphon Jet Flush
- \* 3” High Performance Flushing System
- \* 14¾” (375mm) Rim Height
- \* Large Water Surface
- \* 2½” Wide Fully Glazed Trapway
- \* 12” Rough-in
- \* MaP Score - 800 Grams

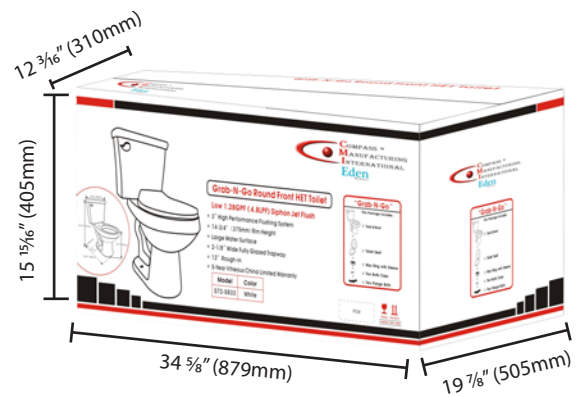

Project / Job Name			
Architect / Engineer			
Contractor			
Model		Qty	
Notes :			



**Round Front Toilet**

**SPECIFICATIONS**

- \* Water Use : 4.8Lpf/1.28Gpf
- \* Trap Diameter : 2 1/8"
- \* Rough-in : 12"
- \* Trap Seal : 2 1/8"
- \* Min. Water Pressure : 20 psi
- \* Water Surface : 7" x 3 5/16"
- \* Flush System : Siphon Jet Gravity Flushing System
- \* Warranty : Five Year Limited Warranty
- \* Material : Tank & Bowl: Vitreous China  
: Toilet Seat: Plastic
- \* Shipping Weight : 78LBS
- \* Shipping Dimensions : 34 5/8" L x 19 7/8" W1  
x 12 3/16" W2 x 15 15/16" H

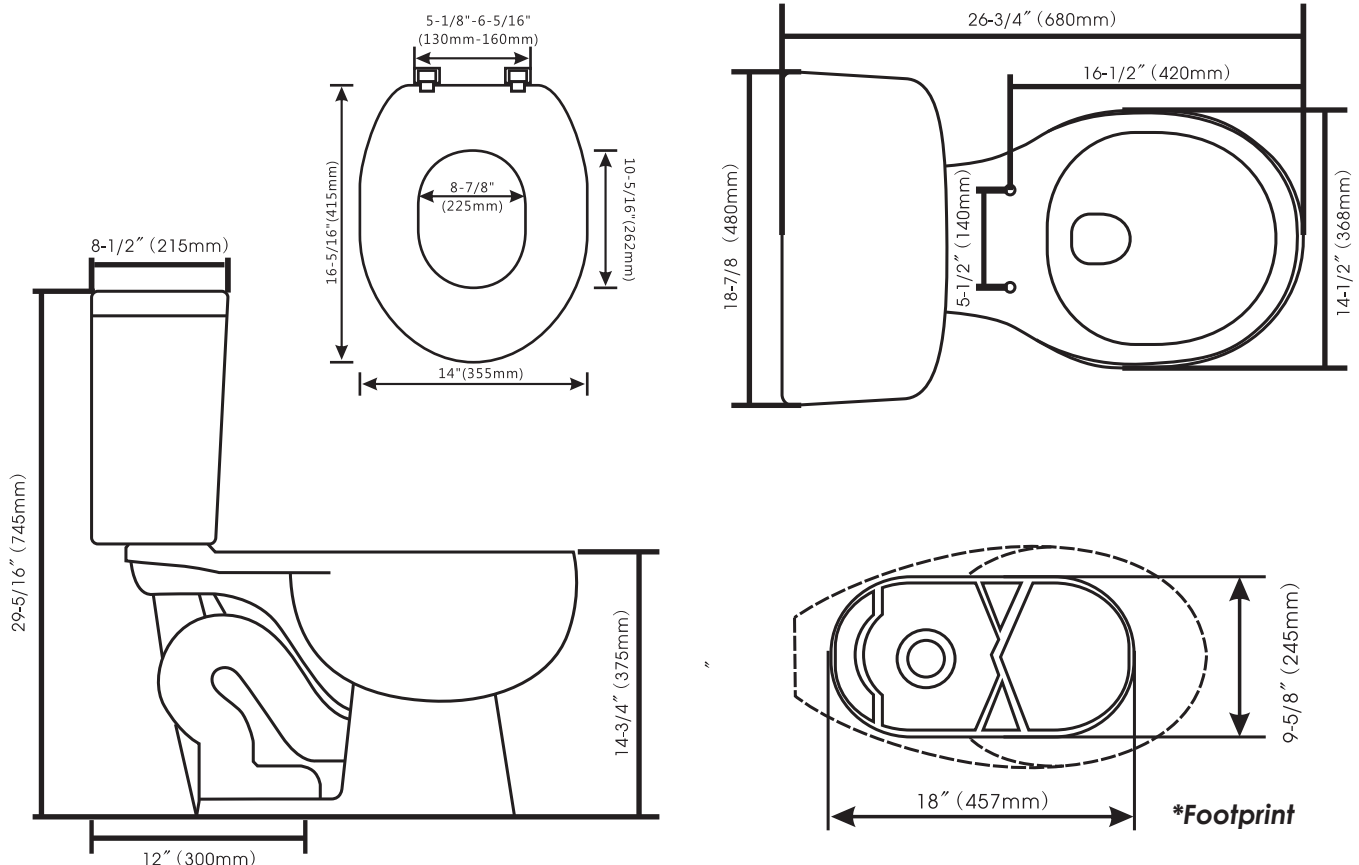

Dimensions In Inches And Millimeters

Dimensions Are Subject To A Variance Of +/-5%



**Elongated Toilet**

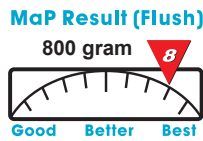

Fixture dimensions and hydraulic performance meet or exceed ANSI/ASME standard A112.19.2M and CAN/CSA B-45 requirements.



<b>Model</b>	<b>Color</b>
572-5834	White

**“Grab-N-Go”**

**This Package Includes :**

- ✧ Tank & Bowl
- ✧ Toilet Seat
- ✧ Wax Ring with Sleeve
- ✧ Two Bolt Caps
- ✧ Two Flange Bolts

**Grab-N-Go Elongated 1.28GPF 3” Flush Toilet**

**DESCRIPTION**

- \* 1.28 GPF (4.8 LPF) Siphon Jet Flush
- \* 3” High Performance Flushing System
- \* 15” (380mm) Rim Height
- \* Large Water Surface
- \* 2 1/8” Wide Fully Glazed Trapway
- \* 12” Rough-in
- \* MaP Score - 800 Grams



Project / Job Name			
Architect / Engineer			
Contractor			
Model		Qty	
Notes :			



**Elongated Toilet**

**SPECIFICATIONS**

- \* Water Use : 4.8Lpf/1.28Gpf
- \* Trap Diameter : 2 1/8"
- \* Rough-in : 12"
- \* Trap Seal : 2 1/8"
- \* Min. Water Pressure : 20 psi
- \* Water Surface : 7" x 3 5/16"
- \* Flush System : Siphon Jet Gravity Flushing System
- \* Warranty : Five Year Limited Warranty
- \* Material : Tank & Bowl: Vitreous China  
Toilet Seat: Plastic
- \* Shipping Weight : 84LBS
- \* Shipping Dimensions : 36"L x 19 7/8" W1  
x 12 3/16" W2 x 15 15/16" H

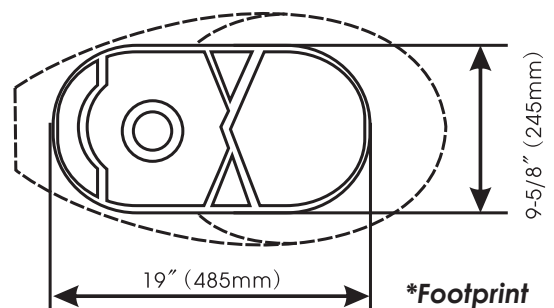
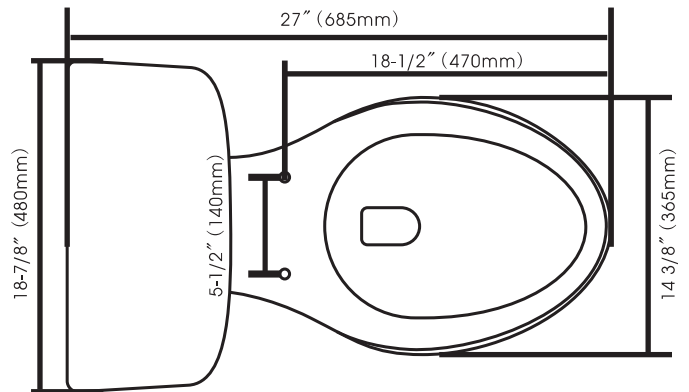
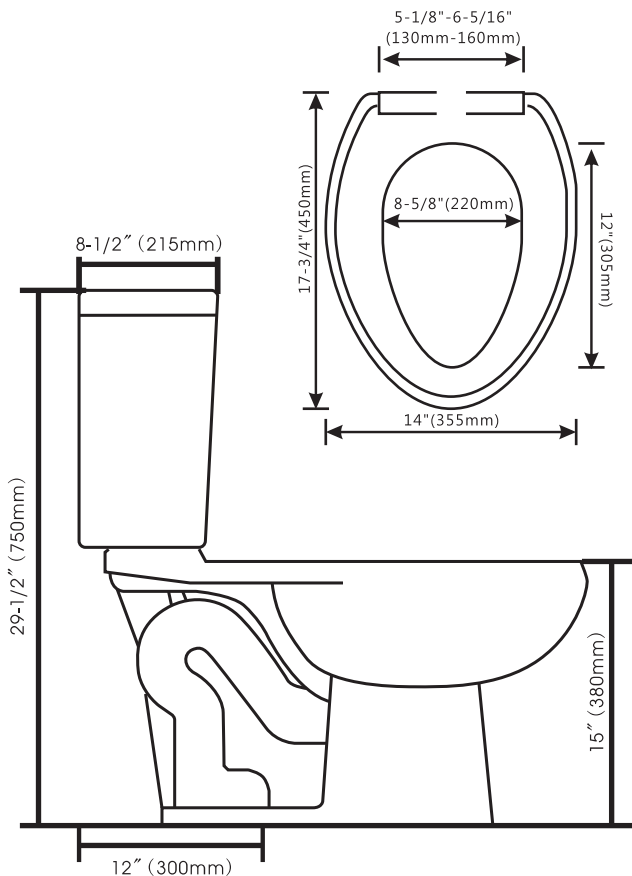



**ADA Elongated Toilet**

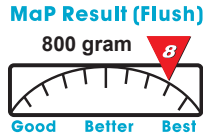

**“Grab-N-Go”**

**This Package Includes :**

- ✳ Tank & Bowl
- ✳ Toilet Seat
- ✳ Wax Ring with Sleeve
- ✳ Two Bolt Caps
- ✳ Two Flange Bolts

Fixture dimensions and hydraulic performance meet or exceed ANSI/ASME standard A112.19.2M and CAN/CSA B-45 requirements.



<b>Model</b>	<b>Color</b>
572-5835	White

**Grab-N-Go ADA Elongated 1.28GPF 3” Flush Toilet**

**DESCRIPTION**

- \* 1.28 GPF (4.8 LPF) Siphon Jet Flush
- \* 3” High Performance Flushing System
- \* 17 1/8” (437mm) Rim Height
- \* Large Water Surface
- \* 2 1/8” Wide Fully Glazed Trapway
- \* 12” Rough-in
- \* MaP Score - 800 Grams



Project / Job Name			
Architect / Engineer			
Contractor			
Model		Qty	
Notes :			



**ADA Elongated Toilet**

**SPECIFICATIONS**

- \* Water Use : 4.8Lpf/1.28Gpf
- \* Trap Diameter : 2 1/8"
- \* Rough-in : 12"
- \* Trap Seal : 2 1/8"
- \* Min. Water Pressure : 20 psi
- \* Water Surface : 7" x 3 5/16"
- \* Flush System : Siphon Jet Gravity Flushing System
- \* Warranty : Five Year Limited Warranty
- \* Material : Tank & Bowl: Vitreous China  
: Toilet Seat: Plastic
- \* Shipping Weight : 90LBS
- \* Shipping Dimensions : 35 7/16" L x 19 7/8" W1  
x 12 3/16" W2 x 18 1/2" H

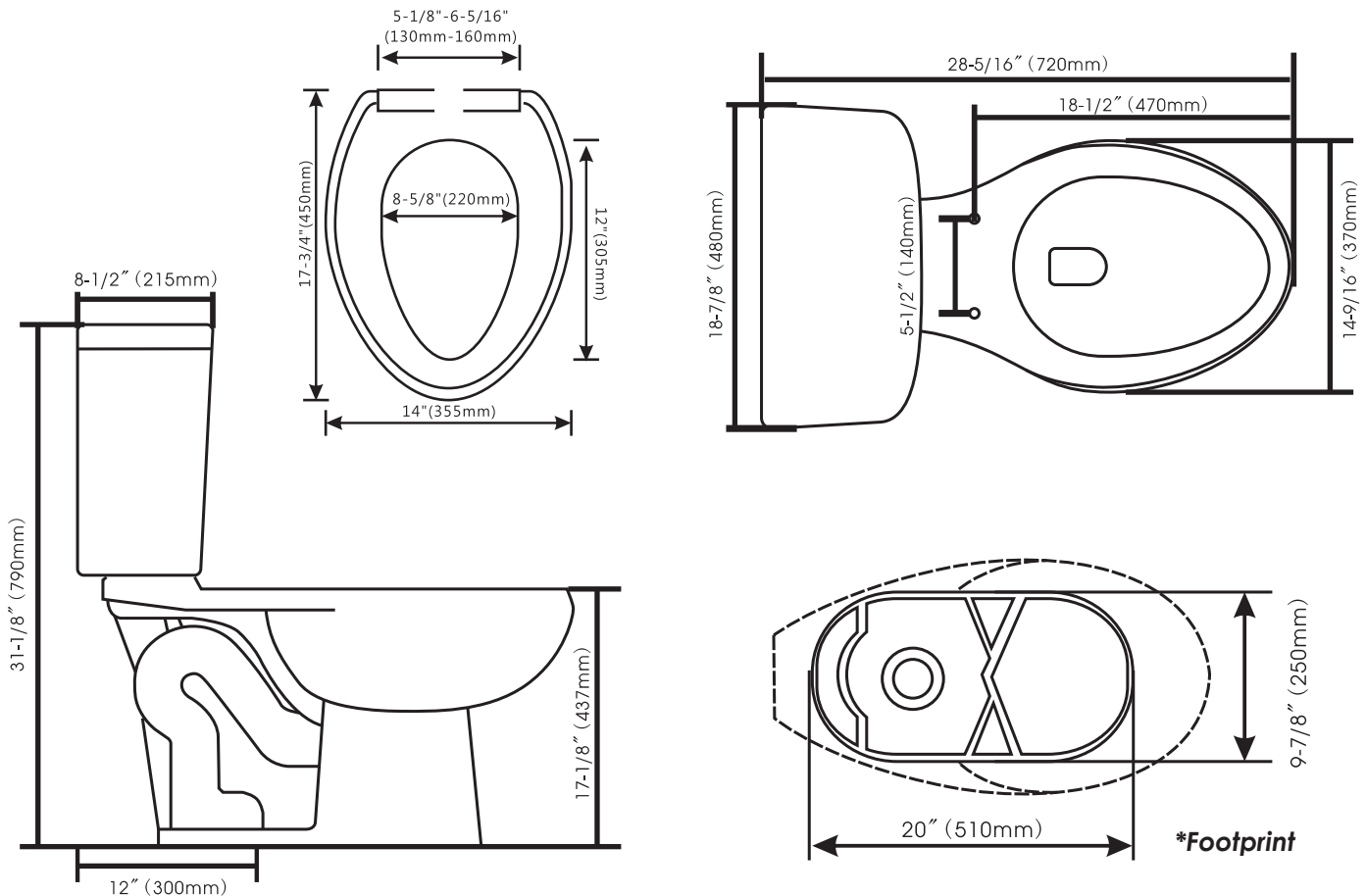

**Dimensions In Inches And Millimeters**

**Dimensions Are Subject To A Variance Of +/-5%**





**20" x 17" Pedestal**

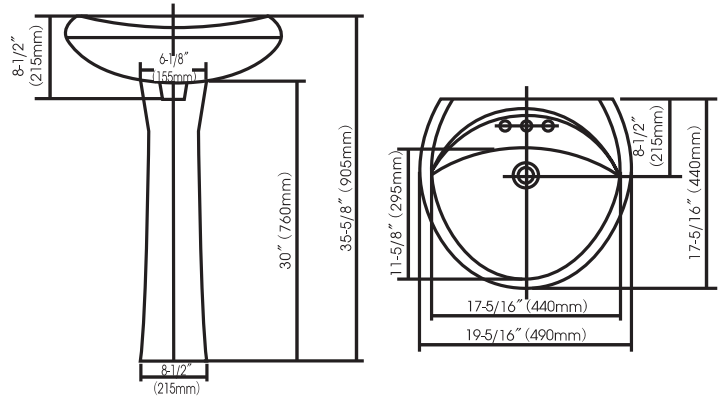

Dimensions In Inches And Millimeters      Dimensions Are Subject To A Variance Of +/-5%

Fixture dimensions and hydraulic performance meet or exceed ANSI/ASME standard A112.19.2M and CAN/CSA B-45 requirements.

	Model	Color	Centerset
Base	561-6924	White	
Bowl	561-6923	White	4"

**Salinas 20" x 17" Pedestal Series**

**DESCRIPTION**

- \* Smoothly Sculptured Pedestal Lavatory
- \* 20"W x 17"D x 35 5/8"H
- \* Deep Bowl with Large Wash Area
- \* Available in 4" Centers Only
- \* Available in White

**DIMENSIONS**

**BOWL**

- \* Length : 19-5/16"
- \* Width : 17-5/16"
- \* Height : 5-5/8"
- \* Net Weight : 22LBS
- \* Shipping Weight : 23LBS

**BASE**

- \* Length : 8-1/2"
- \* Width : 6-1/8"
- \* Height : 30"
- \* Net Weight : 20LBS
- \* Shipping Weight : 21LBS

Project / Job Name			
Architect / Engineer			
Contractor			
Model		Qty	
Notes :			



**22" x 18" Pedestal**

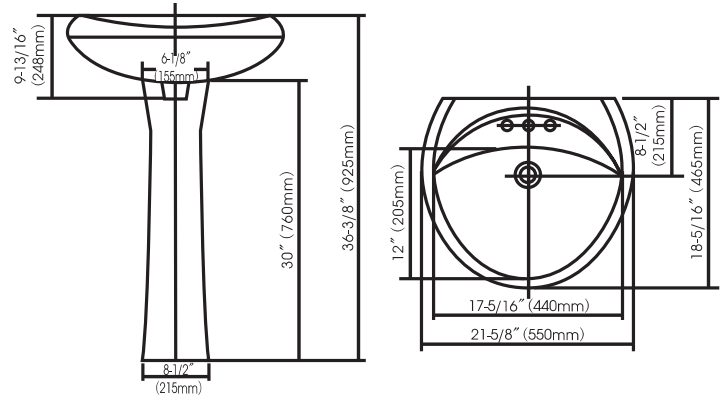

Dimensions In Inches And Millimeters      Dimensions Are Subject To A Variance Of +/-5%

Fixture dimensions and hydraulic performance meet or exceed ANSI/ASME standard A112.19.2M and CAN/CSA B-45 requirements.

	Model	Color	Centerset
Base	561-6924	White	
Bowl	561-6925	White	4"

**Bluffton 22" x 18" Pedestal Series**

**DESCRIPTION**

- \* Smoothly Sculptured Pedestal Lavatory
- \* 22"W x 18"D x 36 3/8"H
- \* Deep Bowl with Large Wash Area
- \* Available in 4" Centers Only
- \* Available in White

**DIMENSIONS**

**BOWL**

- \* Length : 22"
- \* Width : 18"
- \* Height : 5-11/16"
- \* Net Weight : 26.62LBS
- \* Shipping Weight : 27.83LBS

**BASE**

- \* Length : 7-11/16"
- \* Width : 6-11/16"
- \* Height : 26-9/16"
- \* Net Weight : 17.93LBS
- \* Shipping Weight : 19.14LBS

Project / Job Name			
Architect / Engineer			
Contractor			
Model		Qty	
Notes :			



**23" x 19" Pedestal**



Fixture dimensions and hydraulic performance meet or exceed ANSI/ASME standard A112.19.2M and CAN/CSA B-45 requirements.

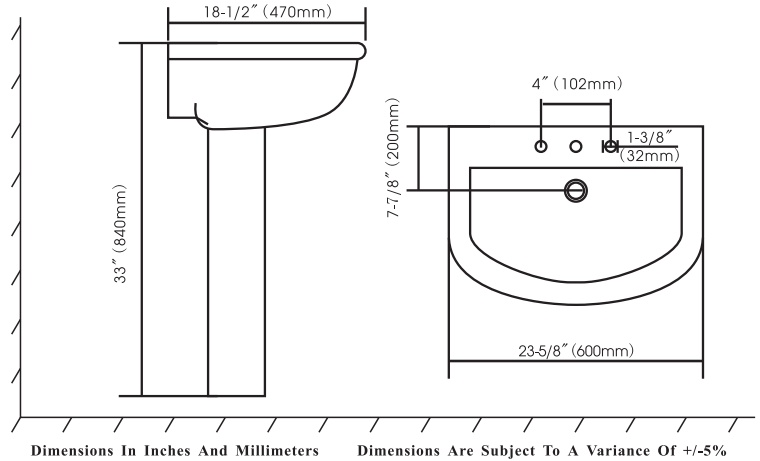

	Model	Color	Centerset
Base	562-6287	White	
Bowl	562-6286	White	4"

**Victoria 23" x 19" Pedestal Series**

**DESCRIPTION**

- \* Smoothly Sculptured Pedestal Lavatory
- \* 22<sup>5</sup>/<sub>8</sub>"W x 18<sup>1</sup>/<sub>2</sub>"D x 33"H
- \* Deep Bowl with Large Wash Area
- \* Available in 4" Centers Only
- \* Available in White

Project / Job Name			
Architect / Engineer			
Contractor			
Model		Q'ty	
Notes :			

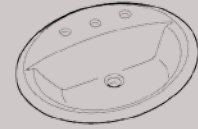

**19" x 19" Drop-in**



Model	Color	Centerset
006-622	White	4"
561-0633	Biscuit	4"

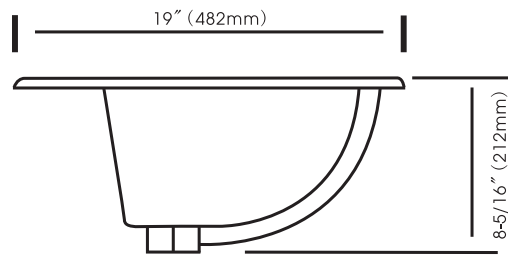
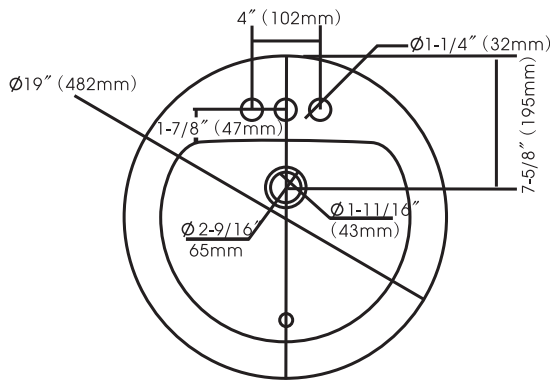

**Oak Lawn 19" Drop-in Round Bowl**

**DESCRIPTION**

- \* 19" Round Self Rimming Drop-in Lavatory
- \* 7<sup>7</sup>/<sub>8</sub>" Depth
- \* 4" Centerset
- \* Inside Bowl Dimension 12<sup>3</sup>/<sub>4</sub>" x 14<sup>3</sup>/<sub>4</sub>"
- \* Gross Weight: 16.5 LBS
- \* ADA Compliant when Installed in a 21" (533 mm) Minimum Depth Countertop
- \* Deep Bowl with Large Wash Area
- \* Available in White or Biscuit
- \* DXF File Available

Project / Job Name			
Architect / Engineer			
Contractor			
Model		Qty	
Notes :			

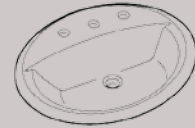

**20" x 17" Drop-in**



Model	Color	Centerset
006-623	White	4"
561-0634	Biscuit	4"

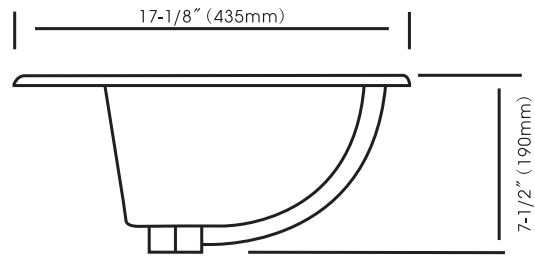
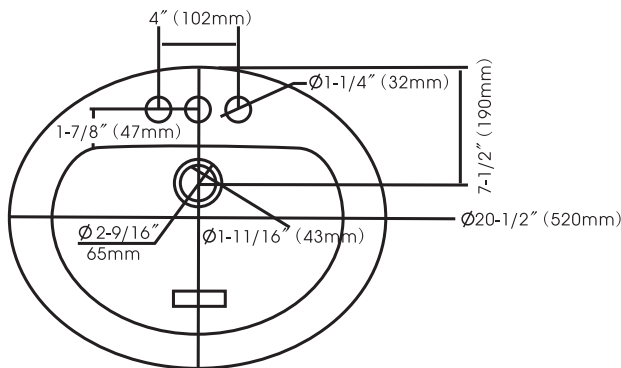

**Oak Lawn 20" X 17" Drop-in Oval**

**DESCRIPTION**

- \* 20" x 17" Oval Self Rimming Drop-in Lavatory
- \* 7 7/8" Depth
- \* 4" Centerset
- \* Inside Bowl Dimension 10 1/2" x 16"
- \* Gross Weight: 16.5 LBS
- \* ADA Compliant when Installed in a 21" (533 mm) Minimum Depth Countertop
- \* Deep Bowl with Large Wash Area
- \* Available in White or Biscuit
- \* DXF File Available

Project / Job Name			
Architect / Engineer			
Contractor			
Model		Qty	
Notes :			

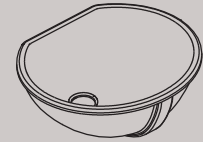

**15" x 12" Under-mount**



Model	Color
561-0584	White
561-0585	Biscuit

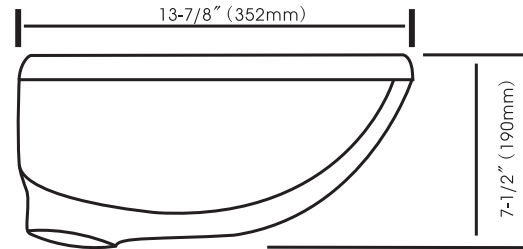
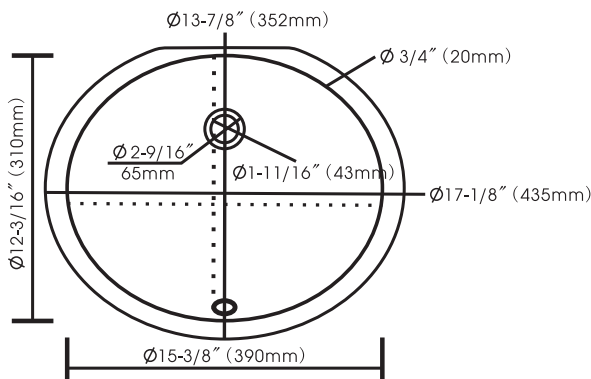

**Forsyth 15" x 12" Under-Mount Bowl**

**DESCRIPTION**

- \* 15" x 12" Under-mount Lavatory with Unglazed Rim
- \* 7½" Depth
- \* Inside Bowl Dimension 15¾" x 12¾"
- \* Gross Weight: 14 LBS
- \* ADA Compliant when Installed in a 21" (533 mm) Minimum Depth Countertop
- \* Flat-Back Rim Allows Positioning of this Lavatory Closer to Faucets
- \* Polished Top Rim for Easier Installation
- \* Deep Bowl with Large Wash Area
- \* Available in White and Biscuit

Project / Job Name			
Architect / Engineer			
Contractor			
Model		Qty	
Notes :			

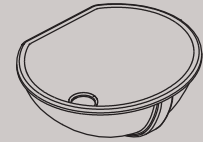

**17" x 14" Under-mount**



Model	Color
561-0409	White
561-0546	Biscuit

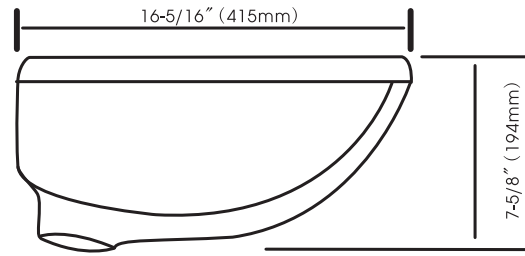
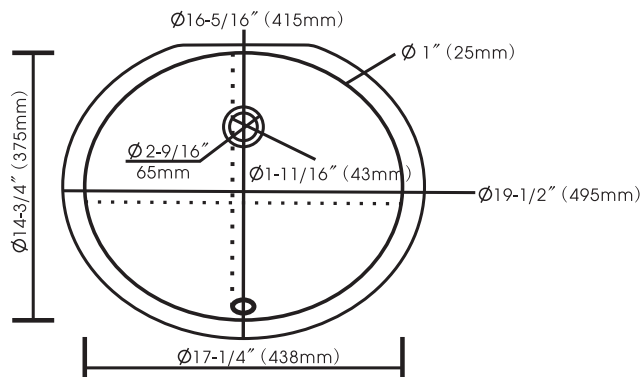

**Forsyth 17" X 14" Under-Mount Bowl**

**DESCRIPTION**

- \* 17" x 14" Under-mount Lavatory with Unglazed Rim
- \* 8¼" Depth
- \* Flat Back Rim Allows Closer Positioning to Faucet
- \* Inside Bowl Dimension 17¼" x 14¾"
- \* Gross Weight: 17"
- \* ADA Compliant when Installed in a 21" (533 mm) Minimum Depth Countertop
- \* Deep Bowl with Large Wash Area
- \* Available in White and Biscuit
- \* DXF File Available

Project / Job Name			
Architect / Engineer			
Contractor			
Model		Qty	
Notes :			

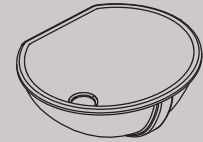

**17" x 13" Under-mount**



Model	Color
561-8826	White
562-0195	Biscuit

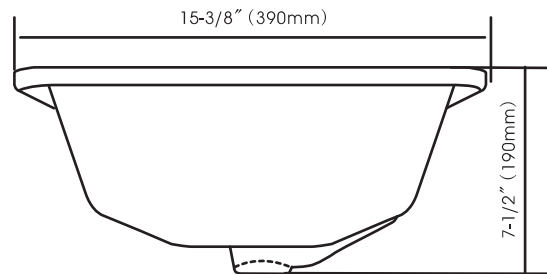
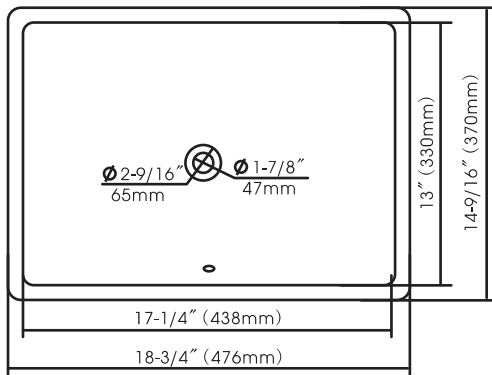

**Forsyth 17" x 13" Under-Mount Bowl**

**DESCRIPTION**

- \* 17" x 13" Under-mount Lavatory with Unglazed Rim
- \* 7½" Depth
- \* Inside Bowl Dimension 17¼" x 13"
- \* Gross Weight: 17.2 LBS
- \* ADA Compliant when Installed in a 21" (533 mm) Minimum Depth Countertop
- \* Polished Top Rim for Easier Installation
- \* Deep Bowl with Large Wash Area
- \* Available in White and Biscuit
- \* DXF File Available

Project / Job Name			
Architect / Engineer			
Contractor			
Model		Qty	
Notes :			



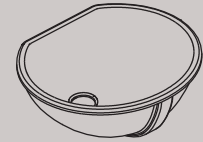

**18" x 12" Under-mount**



Model	Color
562-5796	White
562-6291	Biscuit

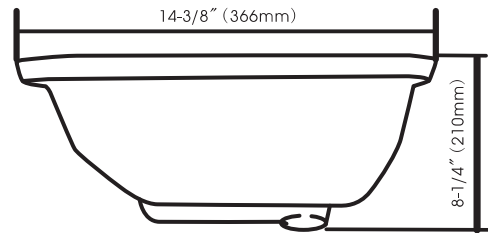
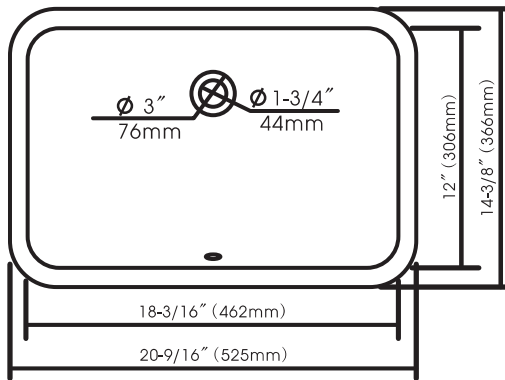

**Forsyth 18" x 12" Under-Mount Bowl**

**DESCRIPTION**

- \* 18" x 12" Under-mount Lavatory with Unglazed Rim
- \* 8" Depth
- \* Inside Bowl Dimension 18" x 12"
- \* Gross Weight: 21 LBS
- \* ADA Compliant when Installed in a 21" (533 mm) Minimum Depth Countertop
- \* Polished Top Rim for Easier Installation
- \* Deep Bowl with Large Wash Area
- \* Available in White or Biscuit
- \* DXF File Available

Project / Job Name			
Architect / Engineer			
Contractor			
Model		Qty	
Notes :			



## LIMITED WARRANTY

### **Vitreous China**

Compass Manufacturing International Vitreous China is warranted to the original consumer purchaser to be free from defects in material and workmanship for as long as the original consumer purchaser owns the home in which the toilet was first installed or for 5 years from the date of purchase.

### **Mechanical Parts**

Mechanical parts of the Compass Manufacturing International toilet are warranted to the original consumer purchaser to be free from defects in material and workmanship for 1 year from the date of purchase.

### **Toilet Seat**

Toilet Seats included in toilet kits are warranted to the original consumer purchaser to be free from defects in material and workmanship for 1 year from the date of purchase. The Toilet Seats included in the Compass Manufacturing International toilet kits are not designed or intended for commercial use; therefore, no warranty is given on the toilet seat if it is used for commercial purposes.

**Toilet Care Tip:** Over time, hard water deposits may clog toilet rim holes and trapways. To clean, purchase a commercial cleaner that's recommended for the removal of hard water deposits. Follow all instructions on the package.

Compass Manufacturing International will replace, free of charge, during the applicable warranty period, any part or finish that proves defective in material and/or workmanship under normal installation, use and service. Compass Manufacturing International recommends using a professional plumber for all installation and repair. Replacement parts may be obtained by emailing the address below, calling the number below or by writing to:

Compass Manufacturing International  
Vitreous China Product Service  
6702 Enterprise Drive  
Louisville, KY 40214  
800.626.3525  
[www.cmiproduct.com](http://www.cmiproduct.com)  
[warranty@cmiproduct.com](mailto:warranty@cmiproduct.com)

### **Vitreous China Product Care**

Rinse thoroughly and use a soft cloth to wipe the product dry after each use.

#### ***Regular Maintenance:***

Remove stains using a cleaning product that contains mild abrasives; rinse and towel dry. Strong abrasive cleaners will scratch and dull the surface. Use toilet bowl cleaners on the inside of the bowl only. Do not use in-tank toilet cleaners as they can damage the flush valve or other working parts. Wipe any splashes of cleaner solutions from plastic or plated surfaces immediately.

#### ***Products to Consider***

Comet Bathroom Cleanser

Formula 409 Antibacterial All Purpose

Windex Original

Soft Scrub Original