

Dual Mount Work Station Sink Installation Instructions

Stainless Steel

Note: This sink is considered a dual mount sink - it can either be installed as an under mount or a traditional top mount.

Top Mount Sink Installations: see page 2.

Under Mount Sink Installations: see page 4.









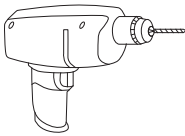
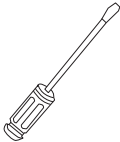

*** BEFORE INSTALLING THE SINK, INSPECT IT FOR DAMAGE. DO NOT INSTALL A DAMAGED UNIT.**

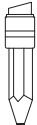
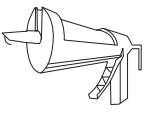
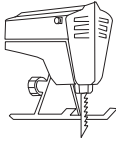
CAUTION: Risk of personal injury. Metal surfaces can be sharp and can cause severe cuts. Please use gloves and handle the sink with care.

Remember, it is your responsibility to follow all local plumbing and building codes.

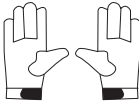
The warranty will be voided if these installation instructions are not followed.

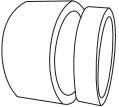
RECOMMENDED TOOLS

1	Drill and Drill Bit				
2	Long Shank Flat Screwdriver				
3	Plumber's Putty/Silicone Sealant				
4	Pencil				
5	Silicone Caulk and Caulk Gun				
6	Saber Saw				
7	Flashlight				
8	Teflon Tape				
9	Safety Glasses				
10	Gloves				
11	Adjustable Wrench				
12	Masking Tape				
13	Sand Paper				

For safety and ease of installation, the manufacturer recommends the use of the helpful tools above.

Have a question? DON'T GO BACK TO THE STORE, WE CAN HELP, just call 1-800-626-3525, 8 a.m. to 5 p.m. EST Monday-Friday, or send an email to Help@cmiproduct.com.

Top Mount Sinks Installation

Step 1

THIS STEP ONLY FOR NEW COUNTER INSTALLATION, IF YOU HAVE AN OLD COUNTER TOP ALREADY CUT, PLEASE GO TO STEP 2.

(For laminate countertop only, other materials should refer to the counter top manufacturer's recommendations.)

- Locate template, put masking tape over the area where the sink cut-out will be. This helps avoid splintering of the laminate when you are cutting. Trace completely around edge of cut-out template.
- It is important that the cut-out be EXACT. First drill a 3/8" diameter hole for the saber saw blade on the inside edge of the cut-out. Cut the sink opening using the cut-out line as a guide. Brace the portion being cut-out to avoid splintering around the edges of hole and sand the edges smooth.
- Go to step 3.

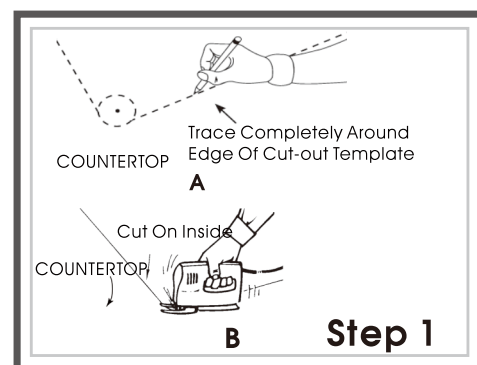

Step 2 (Out with the old)

Here's how to remove the old sink:

- Shut off the water supply valves.
- Disconnect the water supply fittings.
- Disconnect the drain fittings.
- From the underside of the sink, with your flashlight and long screwdriver, loosen and remove the frame clamps or rim fasteners.
- Lift the entire sink out of the countertop.

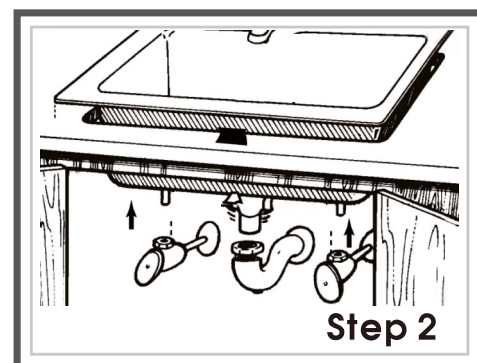

Step 3 (Check your Dimensions)

Check the countertop cut-out opening by placing the sink in the opening to be sure it is sized properly. The sink rim must be set uniformly on the countertop, ensure the corners of the sink sit properly. If the sink does not fit, enlarge the cut-out opening with a saber saw.

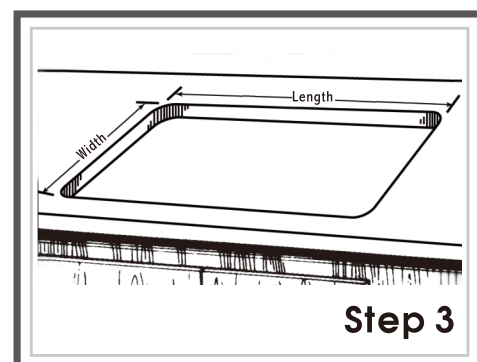

Step 4 (Attach Accessories)

New Accessory Installation: Follow the installation instructions provided with the new accessory.

Reinstalling Old Accessories: Clean all old sealant from accessory. Reinstall using fresh plumber's putty or silicone sealant.

Flexible Supply Lines: Measure from the bottom of the counter-top to the water supply valve. Add 4" to the measurement to allow for movement. Use Teflon tape in all threaded water connections to avoid leaks.

Sink Strainer Installation: Place sealant on bottom of (F) strainer flange (to seal properly) and place in sink opening. From underneath, place (B) rubber washer and (C) friction washer onto (F) strainer flange, then screw on the (A) lock nut while holding the (F) strainer flange firmly in place. Tighten securely. Place (E) tail piece washer (flat side facing up) into the (D) slip nut. Screw the (D) slip nut onto the (F) strainer flange.

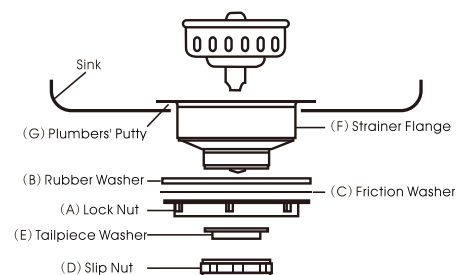
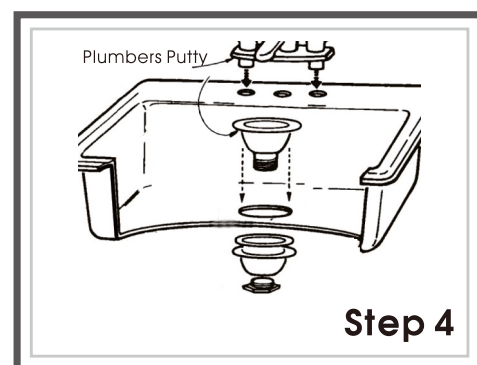

Have a question? DON'T GO BACK TO THE STORE, WE CAN HELP, just call 1-800-626-3525, 8 a.m. to 5 p.m. EST Monday-Friday, or send an email to Help@cmiproduct.com.

Step 5

Apply a small bead of silicone caulk compound completely around all edges of sink opening. Stay approximately 1/4" from cut-out, Use only a 1/8" to 1/4" bead of silicone.

Note: Using too much sealant may keep the sink from properly sealing to the countertop.

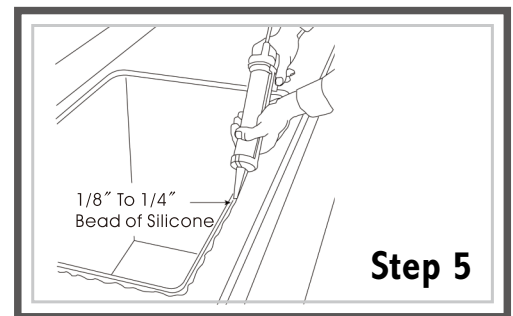

Step 6 (Assemble and Insert Sink Fasteners)

Assemble the screws into the U channel fasteners as shown (1). The screws are designed to insert into the channel fasteners with backward threading, so during mounting they will turn in a counterclockwise direction. Position the fasteners as shown (2). Slide the U channel fasteners into the channel bar from either open end and/or slots in the channel. Hand tighten each fastener onto the channel so that the clamp teeth point toward the U channel.

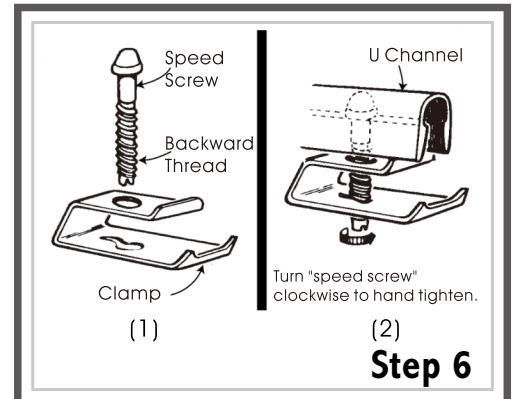

Step 7 (Engage and Tighten Fasteners)

Insert the sink into the countertop. If the cut-out is too small, go to step 3. Do NOT try to force the sink.

Position the fasteners claw end under top edge (See diagram (1) for example).

Locate the fastener in the position as shown in diagram (2).

CAUTION: Improper tightening of channel fasteners could result in improper installation or cause damage to sink.

Tightening Sequence is as follows:

- With U channel fasteners equally spaced, and with one at each end of channel bar, hand tighten channel fasteners, starting at center and working toward sides.
- Re-check sink position on counter top.
- Tighten all channel fasteners an additional quarter turn with a flat head screwdriver, IMPORTANT - DO NOT OVERTIGHTEN.

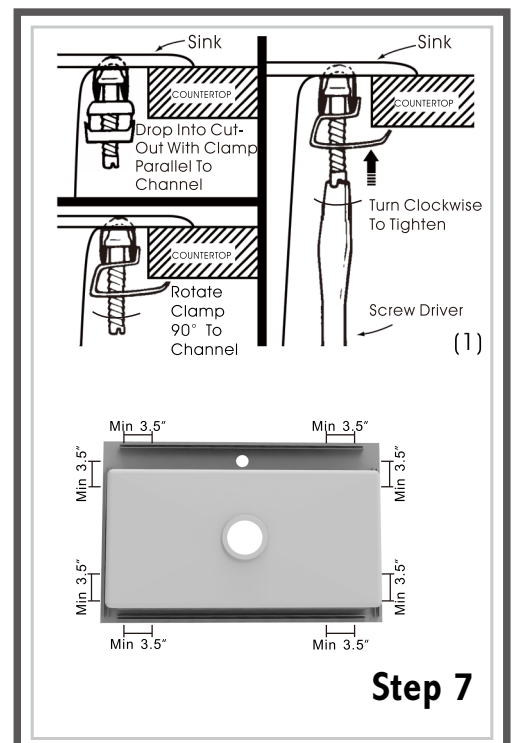

Step 8 (Connect Faucet Supplies and Drain Fittings)

Use Teflon tape at all threaded water connections to avoid leaks. Connect the drain trap fittings. Connect the water supply valves to the faucet. Turn on the water supply valves and check for leaks at all threaded water connections.

Fill the sink bowl with water and check around the drain flange(s) for moisture and for water dripping onto the bottom of the cabinet.

Release water from sink and tighten any leaky connections found.

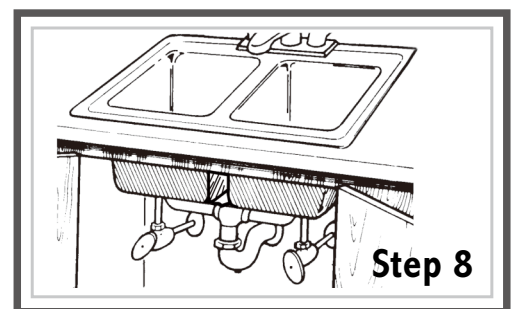

Have a question? DON'T GO BACK TO THE STORE, WE CAN HELP, just call 1-800-626-3525, 8 a.m. to 5 p.m. EST Monday-Friday, or send an email to Help@cmiproduct.com.

Under Mount Work Station Sink Installation

Under mount work station sinks must be installed with reveal for use of accessories.

Reveal - The countertop edge sits approximately 5/8" back from the edge of the sink, exposing the sink rim.

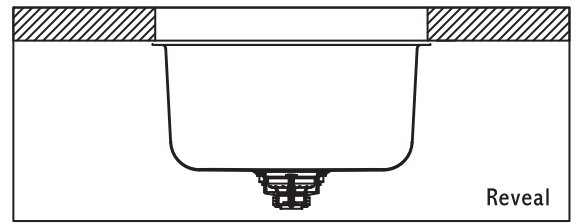

If this is a new countertop installation, please refer to the countertop manufacturer's instructions.

If this is a replacement sink, see Step 2.

Step 1

THIS STEP IS ONLY FOR NEW COUNTERTOP INSTALLATIONS.

Position template on countertop. Locate the template front to rear, so the sink will not interfere with the cabinet.

NOTE: Skip step 2 if this is a new installation.

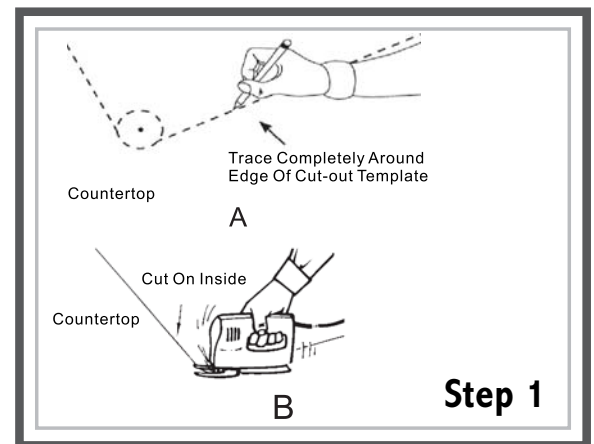

Step 2 (Out with the old)

Here's how to remove the old sink:

- Shut off the water supply valves.
- Disconnect the water supply fittings.
- Disconnect the drain fittings.
- From the underside of the sink, with your flashlight and long screwdriver, loosen and remove the frame clamps or rim fasteners.
- Lift the entire sink out of the countertop.

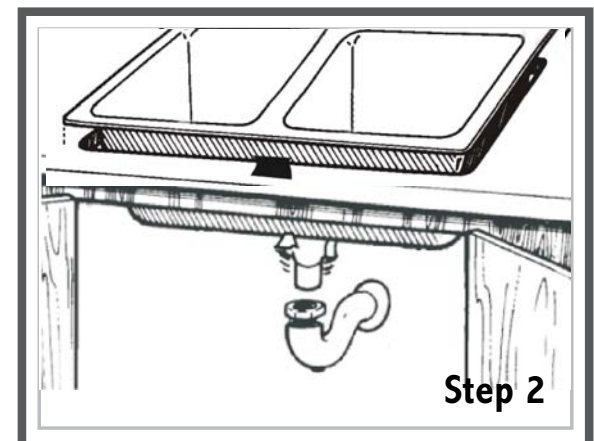

Step 3

Locate and drill the mounting holes (following the countertop manufacturer's instructions) as shown in diagram. Holes should allow even spacing of mounting brackets around the sink. Use the fasteners recommended by the countertop supplier.

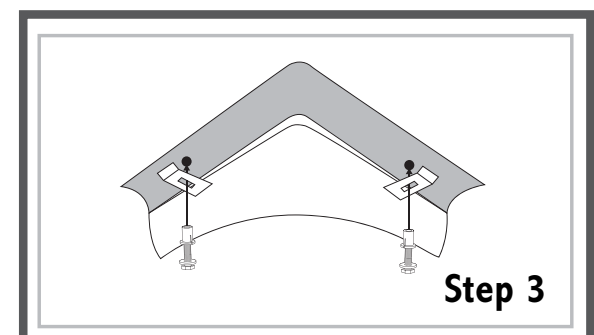

Have a question? DON'T GO BACK TO THE STORE, WE CAN HELP, just call 1-800-626-3525, 8 a.m. to 5 p.m. EST Monday-Friday, or send an email to Help@cmiproduct.com.

Step 4 (Install the Sink)

Clean the bottom of the countertop and the sink rim. Apply a bead of silicone adhesive sealant to the sink rim. Position and align the sink under the countertop. The easiest way to handle the sink is via the drain hole(s).

NOTE:

Metal surfaces can be sharp and can cause severe cuts. Use gloves and handle with care.

Step 5

Slide fasteners over the rim of the sink. Do NOT fully tighten one clip at a time. Partially tighten one clip, then partially tighten the clip across from it, leaving just loose enough to adjust the sink if needed.

Step 6

Check the alignment of the sink to the countertop opening and adjust as needed. Tighten one clip at a time until snug. Repeat the process to tighten the fasteners evenly. Be careful not to over tighten. Remove all excess silicone.

Step 7 (Attach Accessories)

New Accessory Installation: Follow the installation instructions provided with the new accessory.

Reinstalling Old Accessories: Clean all old sealant from accessory. Reinstall using fresh plumber's putty or silicone sealant.

Flexible Supply Lines: Measure from the bottom of the counter-top to the water supply valve. Add 4" to the measurement to allow for movement. Use Teflon tape in all threaded water connections to avoid leaks.

Sink Strainer Installation: Place sealant on bottom of (F) strainer flange (to seal properly) and place in sink opening. From underneath, place (B) rubber washer and (C) friction washer onto (F) strainer flange, then screw on the (A) lock nut while holding the (F) strainer flange firmly in place. Tighten securely. Place (E) tail piece washer (flat side facing up) into the (D) slip nut. Screw the (D) slip nut onto the (F) strainer flange.

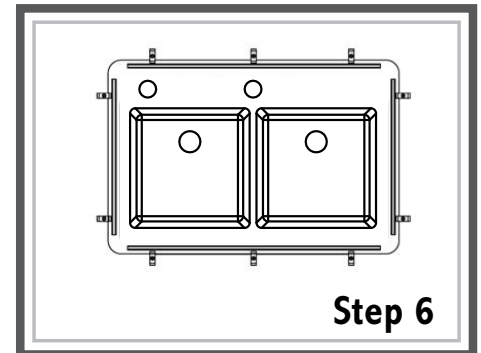
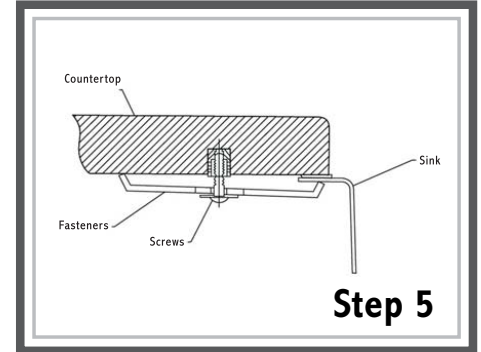
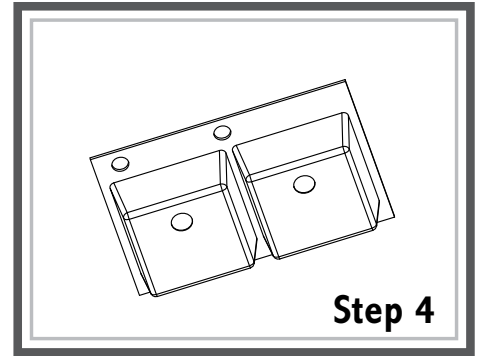

View from under counter.

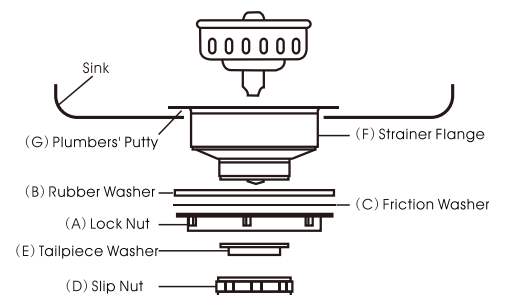
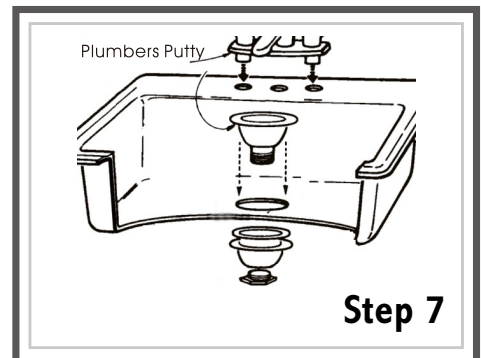

Have a question? DON'T GO BACK TO THE STORE, WE CAN HELP, just call 1-800-626-3525, 8 a.m. to 5 p.m. EST Monday-Friday, or send an email to Help@cmiproduct.com.

Stainless Steel Sink Care:

After Each Use:

- Remove all objects, pads, grids, cloths, etc., from sink.
- Clean with light soap solution, rinse, drain all water and towel dry.

Regular Maintenance:

Side Walls and Bottom of Sink: Remove stains using a cleaning product that contains mild abrasives; always wipe in grain direction; rinse well and towel dry. For stubborn stains or scratches use a fine grit scrubbing pad following direction of sink grain finish. Pay careful attention to the directional change.

Mineral Deposits: Use a cleaning product that contains mild abrasives or a light solution of vinegar and water (1:20 ratio); rinse well and towel dry.

CAUTION: Stainless steel requires exposure to air; DO NOT leave items, objects, cloths, mats, water, pots and pans, cast iron, knives, etc., in sink when not washing. Some items void stainless steel from oxygen and can cause pitting or rusting.

DO NOT :

- Use steel wool or other metal or coarse scouring pads.
- Stand on or in sink when cleaning windows, reaching for top shelf, painting, etc.
- Drop heavy objects in sink as this will cause denting.
- Leave water, bleach, other cleaners, or chemicals of any type in sink; always rinse sink after any use and dry with towel.
- Use concentrated bleach; always dilute with water and rinse thoroughly after use.
- Use any acids, drain cleaners, harsh chemicals, paint removers, metal cleaners, etc., in sink.
- Drop sharp objects in sink or use as a cutting surface.

Lifetime Limited Warranty

The manufacturer warrants that the parts and assemblies of this product will be free from defects in material and workmanship under normal household use for as long as it is owned by the original consumer purchaser.

This warranty covers the original purchaser with original receipt only and does not include business, commercial or industrial use of this product. This warranty shall not apply to goods which have been subject to accidents, negligence or improper installation. Our responsibility under this warranty is limited only to the replacement of parts and no other costs. Should a malfunction occur within the time covered by this warranty, replacement parts may be obtained from the Customer Service Department 1-800-626-3525 or email warranty@cmiproduct.com. The manufacturer will, at its discretion, provide replacement parts for installation by the consumer for any parts that prove defective under normal usage and care with new or equivalent parts.

Revised on 03/04/2021

Have a question? DON'T GO BACK TO THE STORE, WE CAN HELP, just call 1-800-626-3525, 8 a.m. to 5 p.m. EST Monday-Friday, or send an email to Help@cmiproduct.com.