



LIMITED LIFETIME WARRANTY

Compass Manufacturing International warrants to the original consumer purchaser that the faucet be free from defects in material and workmanship for as long as the original consumer purchaser owns the home in which the faucet was first installed.

In the event that Freendo faucets are used in a Commercial Application, this warranty is limited for a period of 5 years, unless otherwise specifically stated in the catalog and/or price book.

Compass Manufacturing International will replace, free of charge, during the applicable warranty period, any part or finish that proves defective in material and/or workmanship under normal installation, use and service. This warranty shall not apply to goods which have been subject to accidents, negligence or improper installation. Compass Manufacturing International will not be liable for other damages or losses, including, but not limited to: labor charges and/or damages incurred in installation, repair or replacement as well as any other kind of loss or damage. Proof of purchase from the original consumer purchaser must be made available for all warranty claims.

Compass Manufacturing International recommends using a professional plumber for all installation and repair. Compass Manufacturing International will, at its discretion, provide new or equivalent replacement parts for any product that proves to be defective under normal usage and service. Replacement parts may be obtained by emailing the address below, calling the number below or by writing to:

Compass Manufacturing International
Freendo Product Service
6702 Enterprise Drive
Louisville, KY 40214
800.626.3525
warranty@cmiproduct.com

Revised 08/08/19

warranty@cmiproduct.com

© Compass Manufacturing International

800.626.3525



Model No. : 192-6449 Polished Chrome
192-6450 Brushed Nickel Spotless PVD™
192-6451 Oil-Rubbed Bronze



**Contractor Trim Pack for
Single Handle Pressure Balanced Tub &
Shower Set**



Helpful Information

Helpful Tools

Tools:

Gather the necessary tools as shown below to complete the installation of this faucet. Some may not be needed depending on the model of faucet you are installing.



Plumber's Putty
and/or Silicone



Flashlight



Basin Wrench



Safety Glasses



Screwdriver



Pliers



Channel Locks



Adjustable Wrench

Maintenance

Your new faucet is designed for years of trouble-free performance. Keep it looking new by cleaning it periodically with a soft, damp cloth. Avoid abrasive cleaners, steel wool and harsh chemicals as these will dull the finish and void your warranty.

Safety Tips

- If you use soldering for the installation of the faucet, the seats, cartridges and washers will have to be removed before using flame. Otherwise, the warranty will be void on these parts.
- Protect your eyes with safety glasses when cutting or soldering water supply line.
- Cover your drain to avoid losing parts.

Important Points

Prior to beginning installation, turn off the cold and hot water lines and turn on the old faucet to release built-up pressure. When installing your new faucet, turn the connector nuts finger tight, then use a wrench to anchor the fitting and a second wrench to tighten the nut one additional turn. Connections that are too tight can compromise the integrity of the system. Wrap all threaded connections with teflon tape. Always wrap in a clockwise direction.

5

Trouble-Shooting

If the instructions were followed carefully and the faucet does not work properly, try these corrective steps.

NOTE: This troubleshooting guide is intended to cover issues that may occur once the valve and trim are installed. Due to this some parts mentioned will be found in the valve pack.

Problem	Cause	Action
Leaks underneath handle.	The locknut sleeve has come loose or the o-ring on the cartridge (#7) is dirty or twisted.	If the locknut sleeve is loose, tighten it. If the locknut sleeve is tight or still leaking after it has been tightened, clean the O-ring on the cartridge (#7) with warm white vinegar or replace the cartridge (#7).
Water will not shut off completely.	The rubber valve seat at the base of the cartridge (#7) is dirty or broken.	Remove the handle (#10) and the cartridge (#7). Clean the rubber valve seat with warm white vinegar or replace the cartridge (#7).
Water temperature can not be adjusted, or no hot or cold water.	Dirty cartridge (#7).	Turn off the water supply. Remove the cartridge (#7) and soak in warm white vinegar for 4 hours. Every 30 minutes, while the cartridge is submerged in the vinegar, rotate the stem on and off 10 times. Verify the pressure balance spool is moving freely (located at the bottom of the cartridge (#7)). Reinstall the cartridge (#7). Turn the water supply on.

Have a question? DON'T GO BACK TO THE STORE, WE CAN HELP, just call 1-800-626-3525 ,8 a.m. to 5 p.m. EST Monday-Friday, or send an email to Help@cmiproduct.com.

4

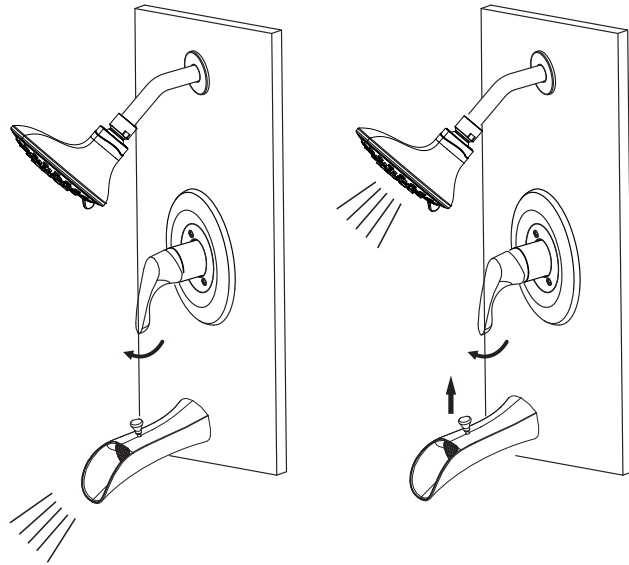

Turn on the water and check for leaks. If there are leaks, please reinstall.

Adjusting hot water stop.

Hot Water Adjustment

Position In The Middle Is Recommended

Cold Water Adjustment

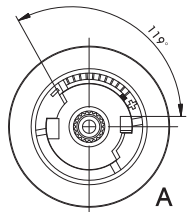

High Temperature setting
(Factory setting)

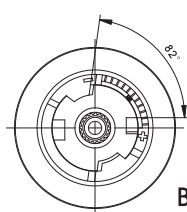

Average Temperature setting

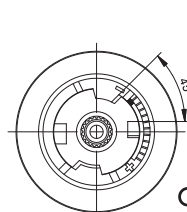

Low Temperature setting

By default, the temperature limiting device is set to the highest temperature (A). In order to reduce the temperature, remove the temperature limiting device and turn clockwise to the desired position (B or C).

1

Parts Diagram / List

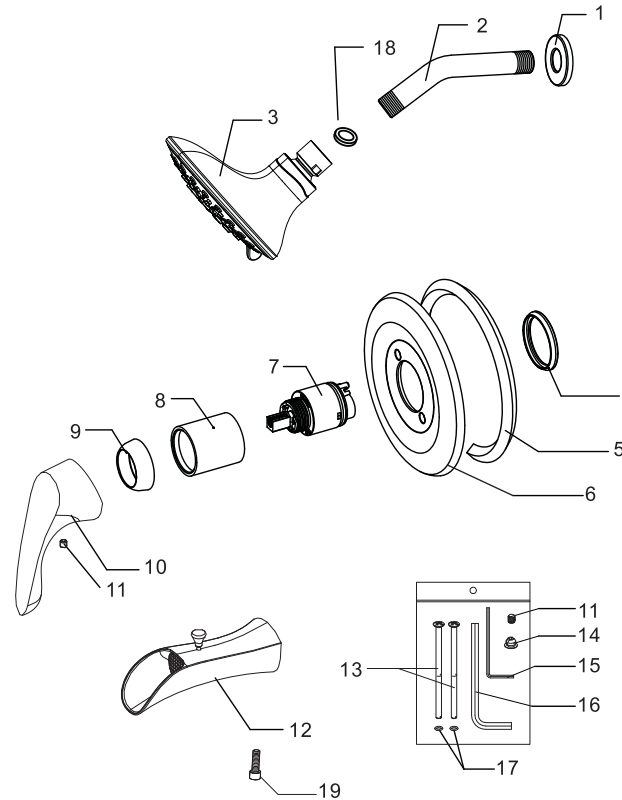

No.	Part Name
1	Shower Arm Flange
2	Shower Arm
3	Shower Head
4	Sealing Ring
5	Sealing Ring
6	Escutcheon
7	Cartridge
8	Cartridge Sleeve
9	Trim Cap
10	Handle
11	Set Screw
12	Tub Spout
13	Escutcheon Screw
14	Hot/Cold Button
15	Allen Wrench
16	Allen Wrench
17	Escutcheon Screw O-rings
18	Rubber Washer
19	Screw

2

Installation Instructions

1.

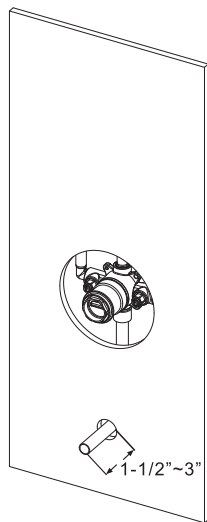

2.

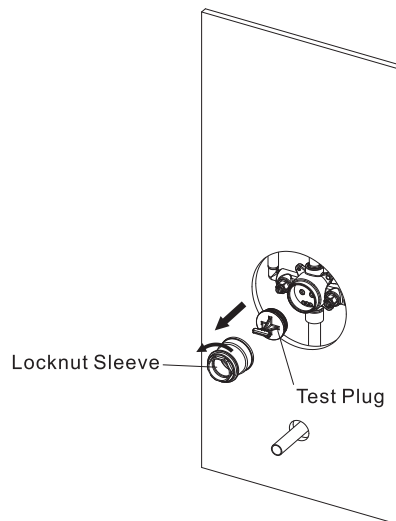

1. Install a supply pipe for the spout. Use the proper length pipe so that it will extend 1-1/2" - 3" from the finish wall.

Note: In order to assure proper function, piping from the bottom port of valve to tub spout outlet must be either 1/2" nominal copper pipe or 1/2" iron pipe. **DO NOT USE PEX FOR THE TUB SPOUT DROP.**

2. Remove the locknut sleeve and test plug as shown.

Note: DO NOT DISCARD locknut sleeve. This item is used to secure the cartridge (#7).

3

Installation Instructions

3.

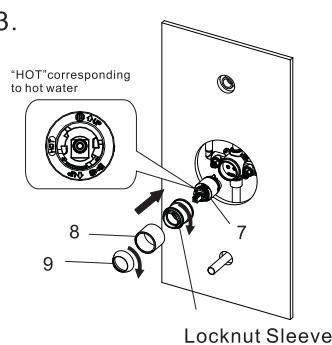

4.

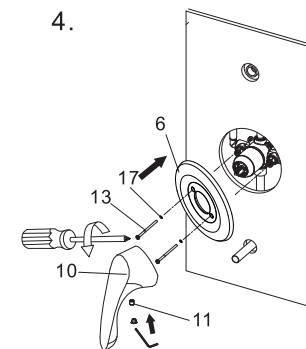

5.

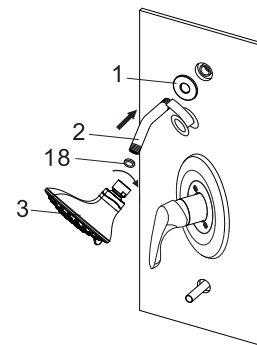

6.

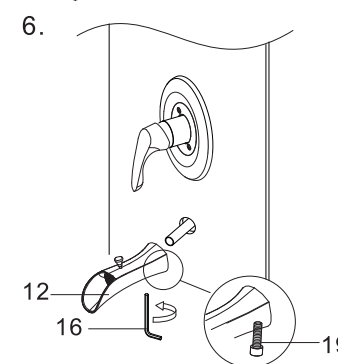

3. Insert the cartridge (#7) into the valve body. Be sure the word "hot" is on the hot water supply side. Screw the locknut sleeve onto the valve body. Slide the cartridge sleeve (#8) over the locknut sleeve and screw on the trim cap (#9). See diagram for visual.

Note: Close the bathtub drain to avoid losing parts.

4. Install the escutcheon (#6) and secure it using the escutcheon screws (#13) with the escutcheon screw O-rings (#17). Turn the valve to the off position. Install the handle (#10) and secure it with the set screw (#11).

5. Slide the shower arm flange (#1) over the longer end of the shower arm (#2). Apply teflon tape to both ends of the shower arm (#2). Install the shower arm (#2) to wall. Install the shower head (#3) to the shower arm (#2).

Note: Ensure the rubber washer (#18) is between the shower arm (#2) and the shower head (#3).

6. Slide the tub spout (#12) onto the nipple. Secure it with the screw (#19) using the allen wrench (#16).